

Monteringsvejledning til Thor hæve sænkestel

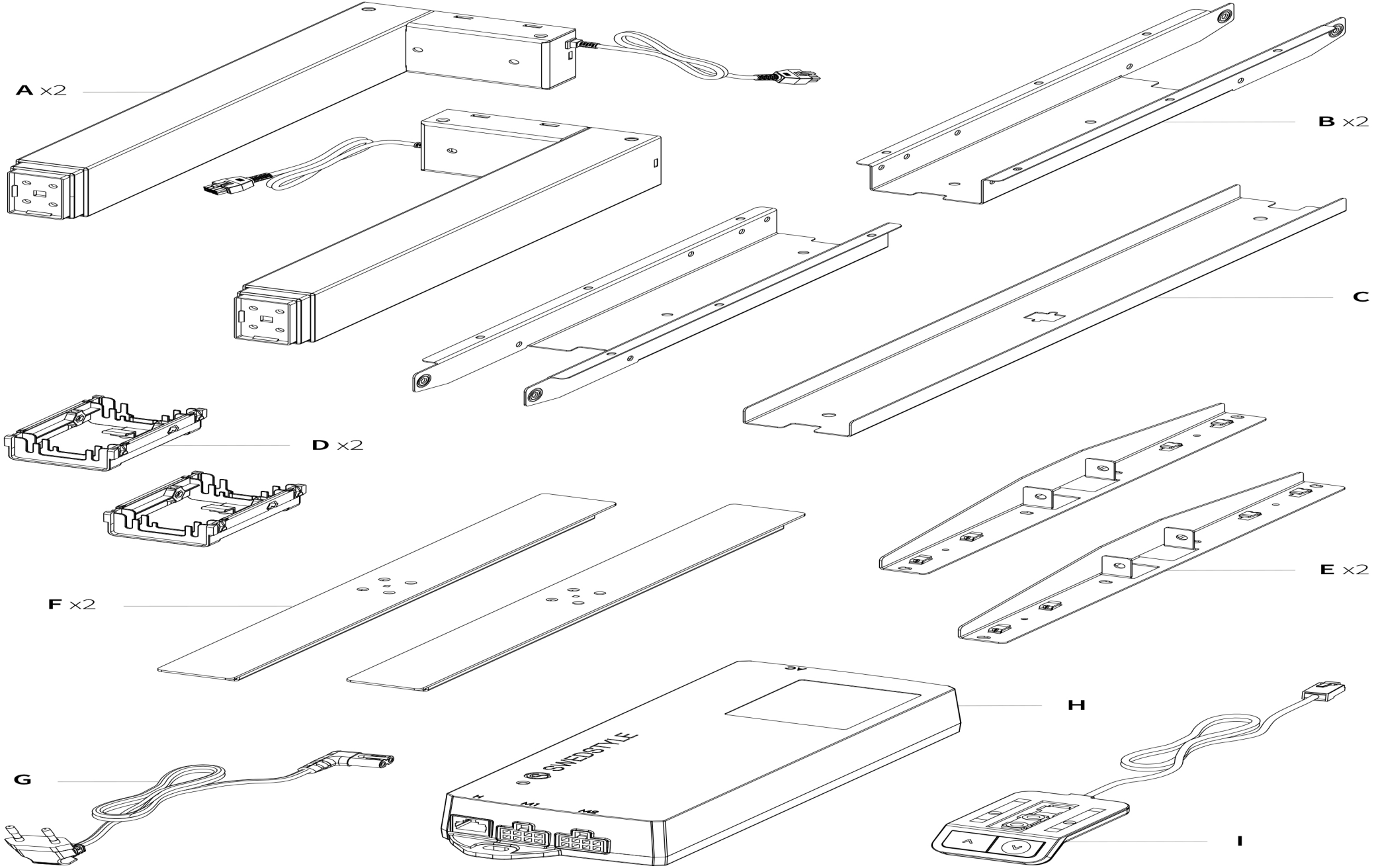

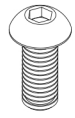

J x12

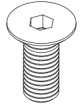

K x8



L x2



M x18

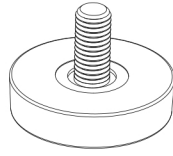

N x4

1.

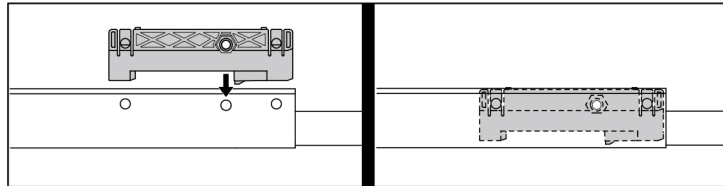
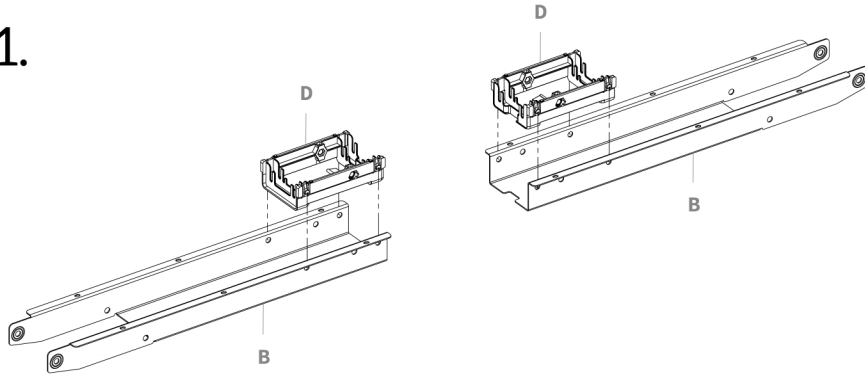

2.

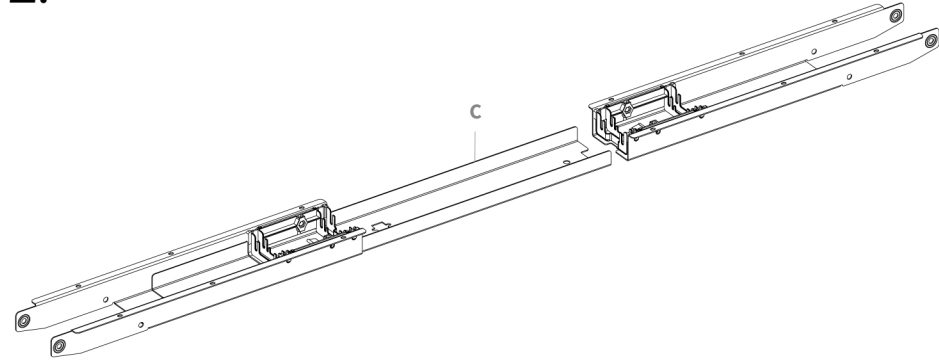

3.

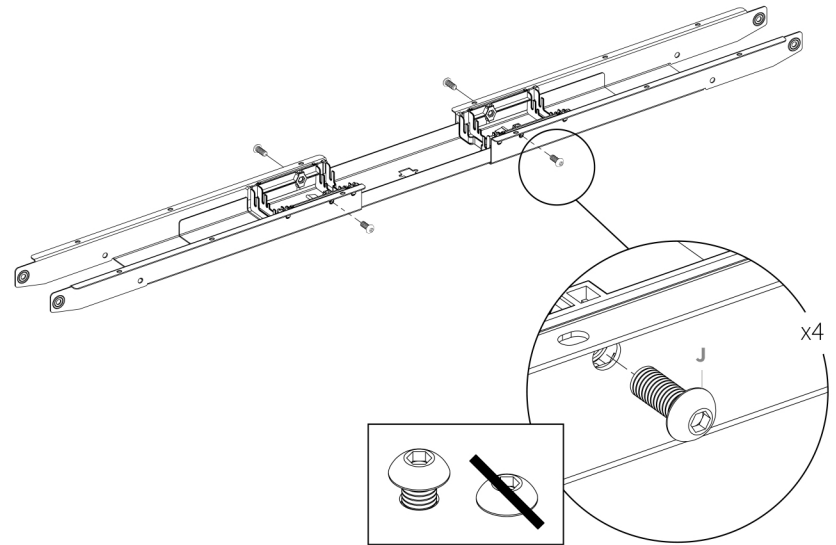

4.

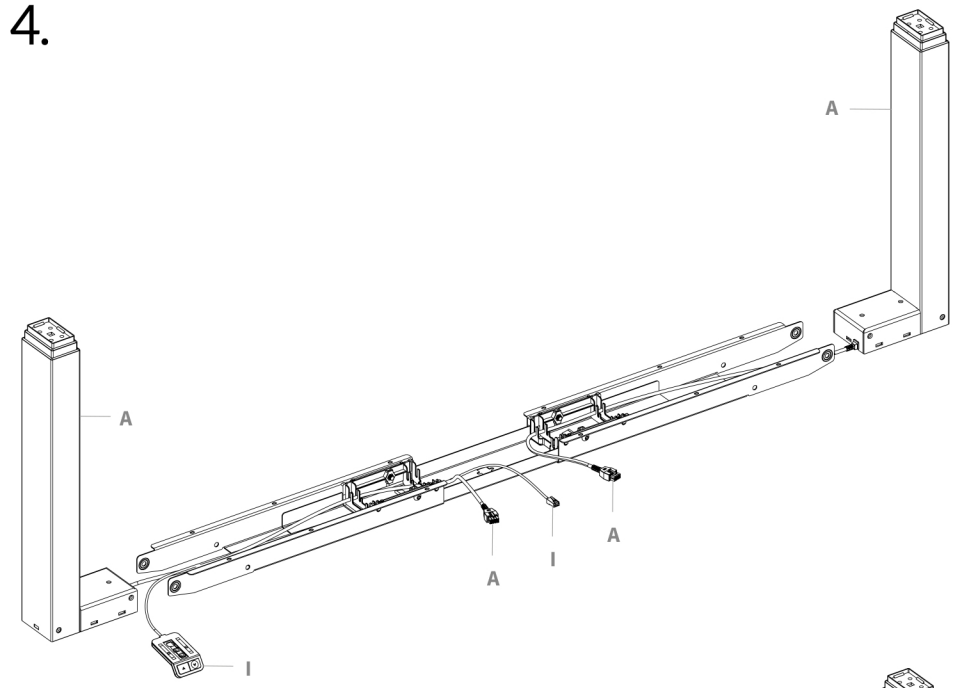

5.

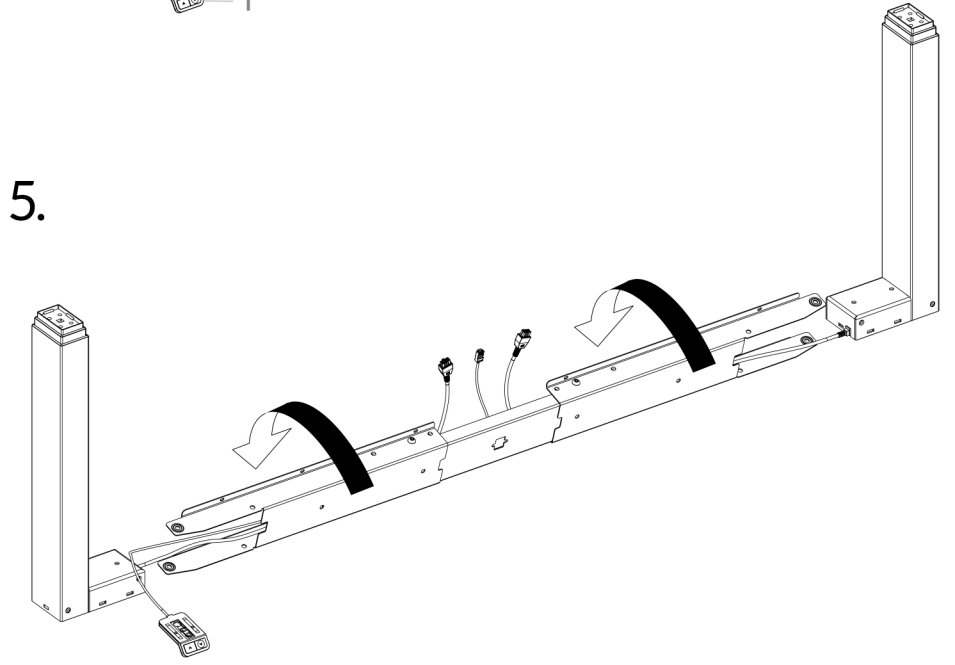

6.

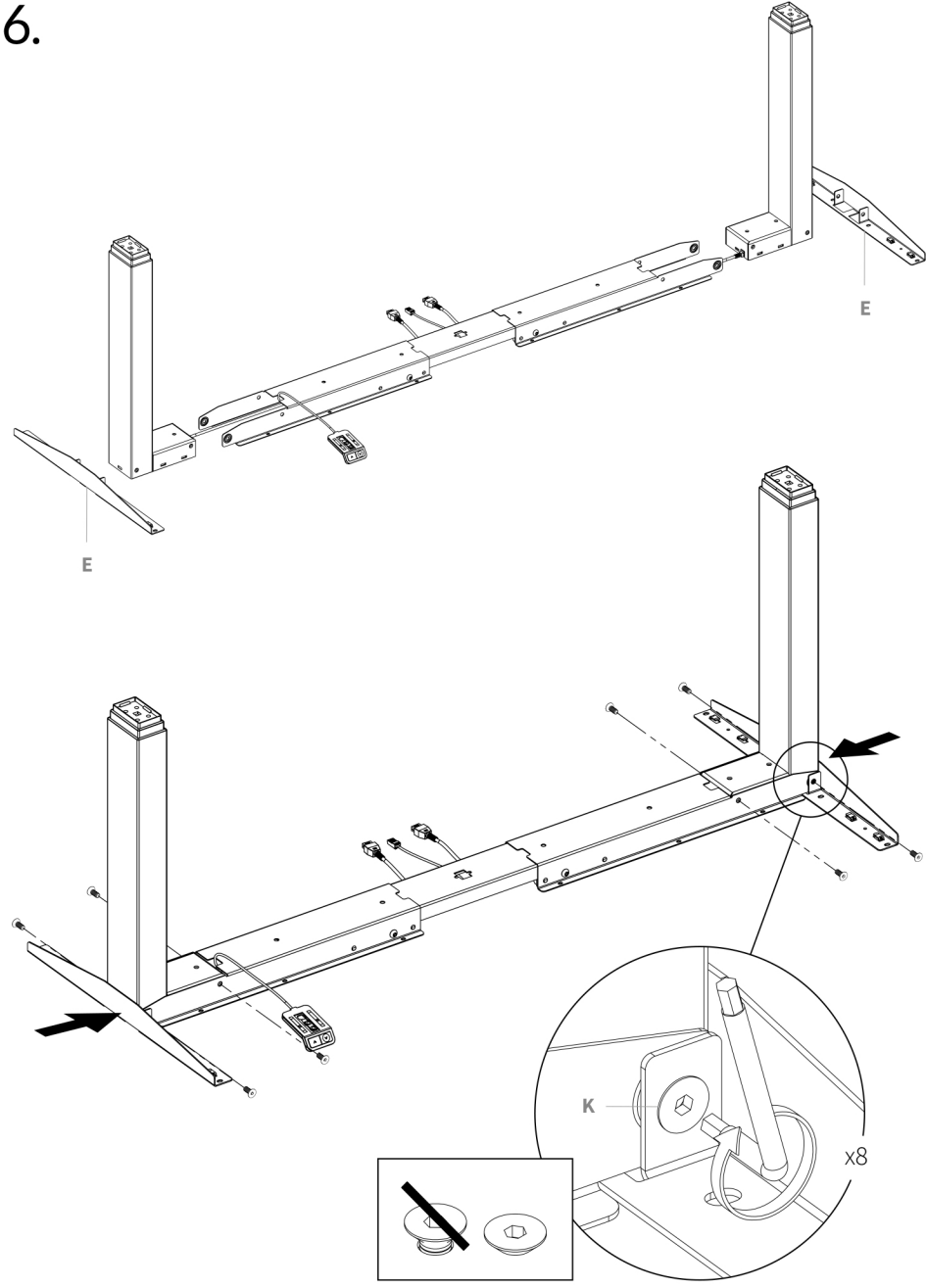

7.

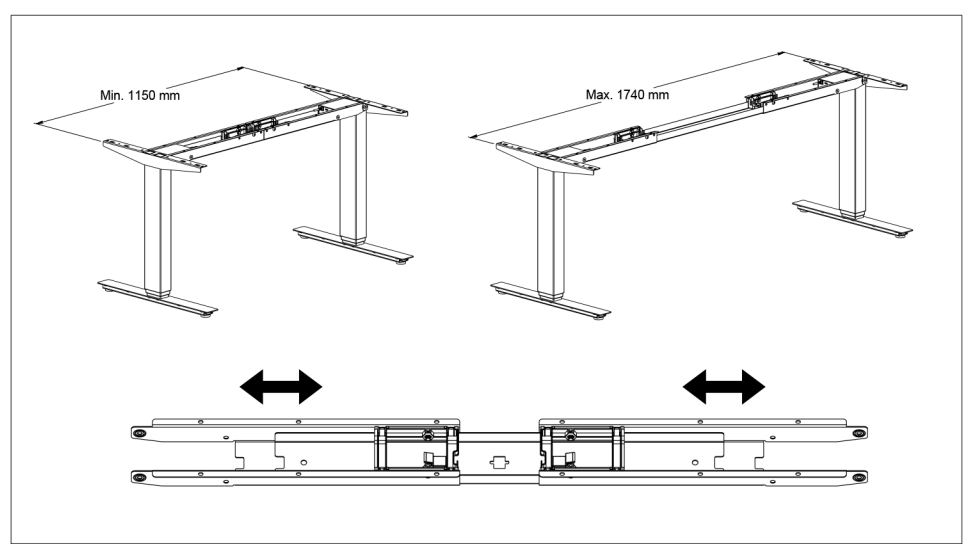
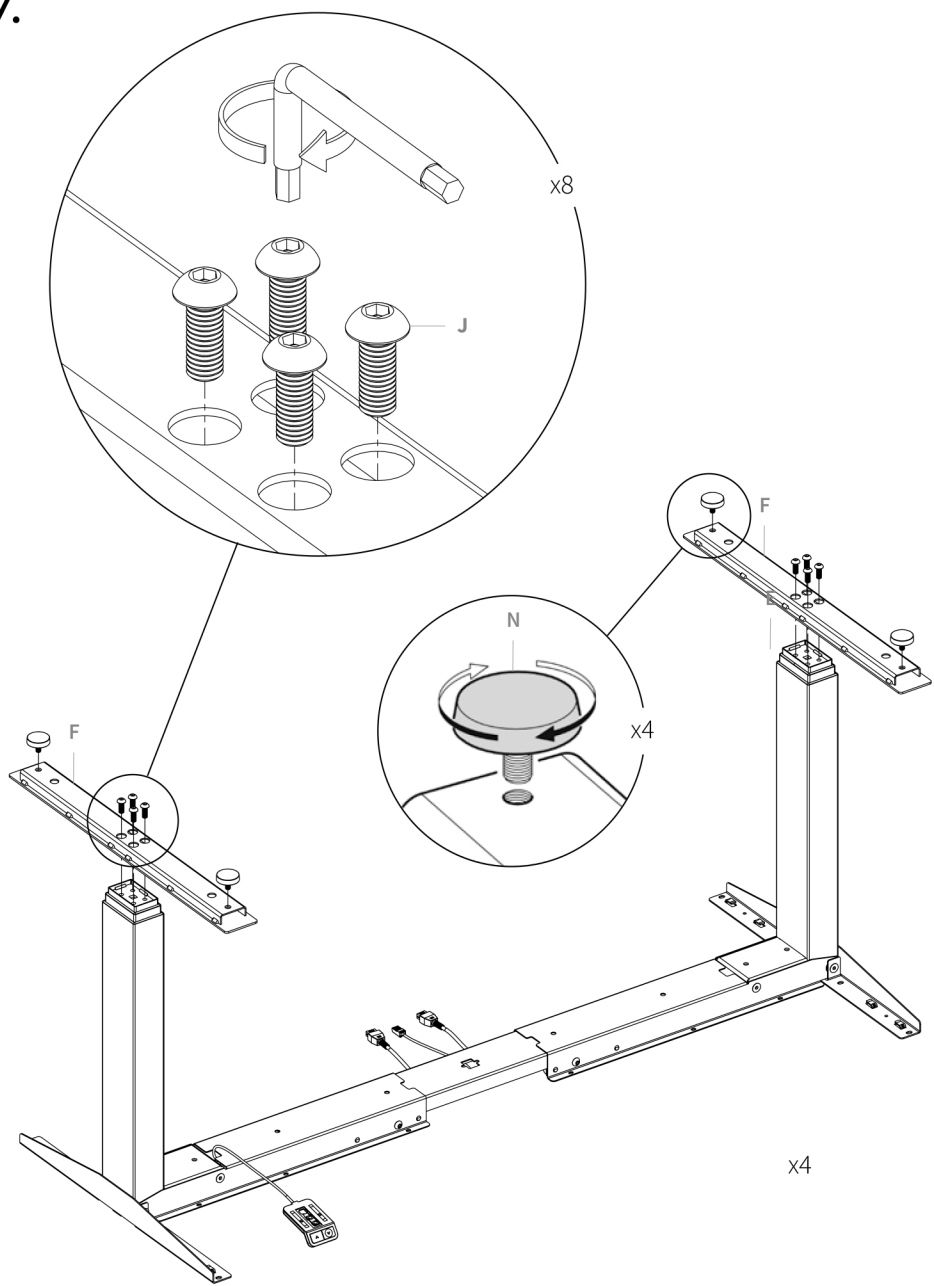

8.

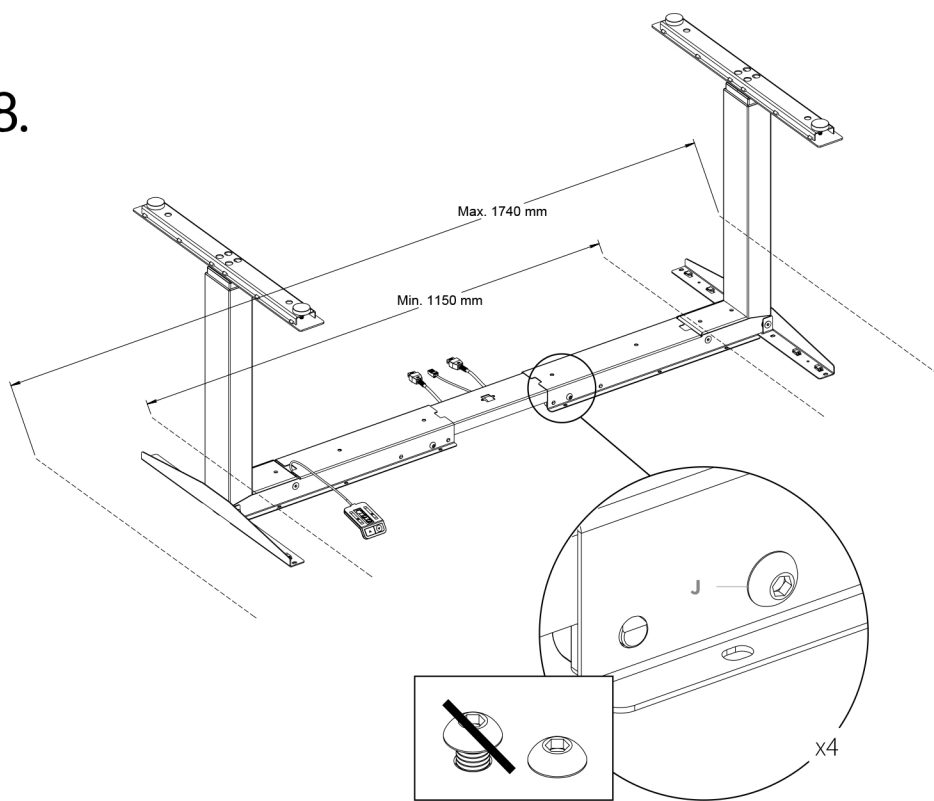

9.

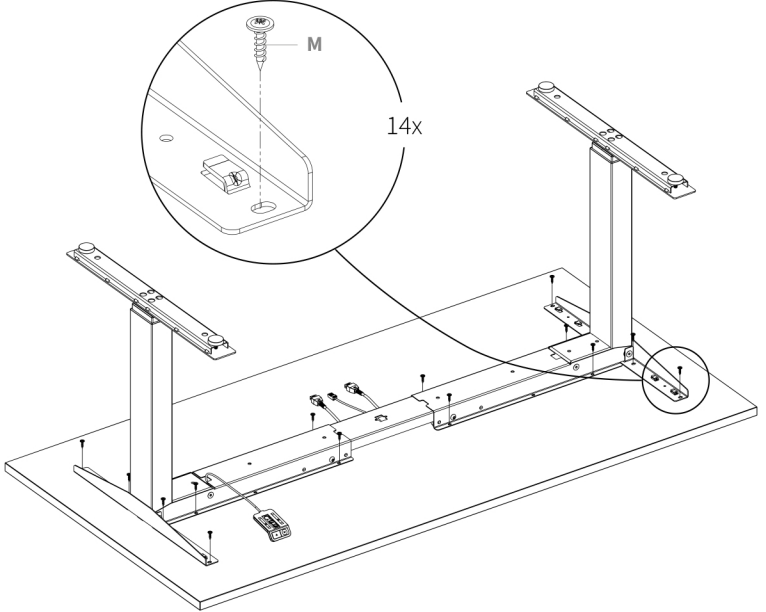

! **NOTE** Before turning the table top upside down, place something underneath to protect the surface.
OBS Placera något skyddande på golvet för att undvika skador på bordsskivan vid montering av stativ.
ACHTUNG Legen Sie zum Schutz der Tischplatte etwas unter bevor Sie diese zur Montage des Gestelles positionieren!

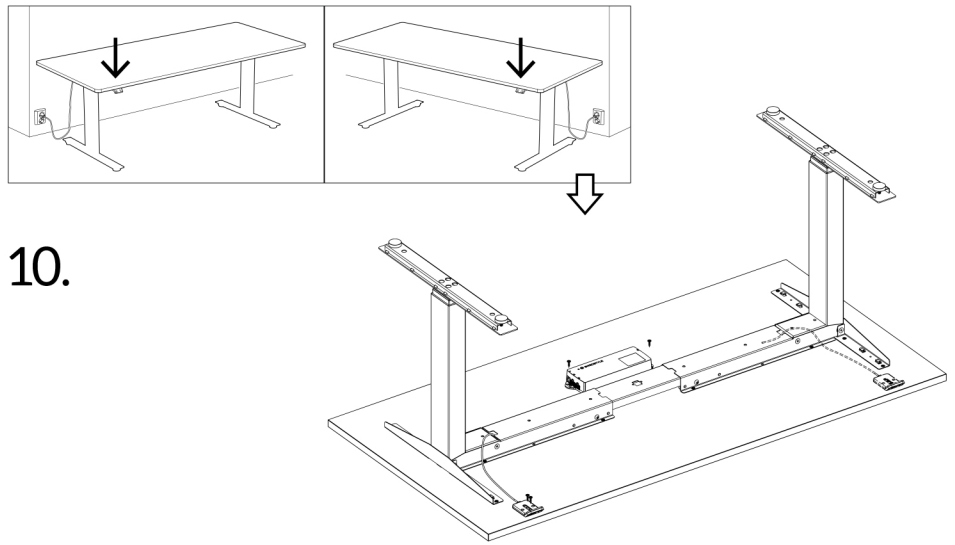

11.

Options for mounting the hand control
 Alternativ vid montering av handkontroll
 Optionen zur Montage der Handbedienung

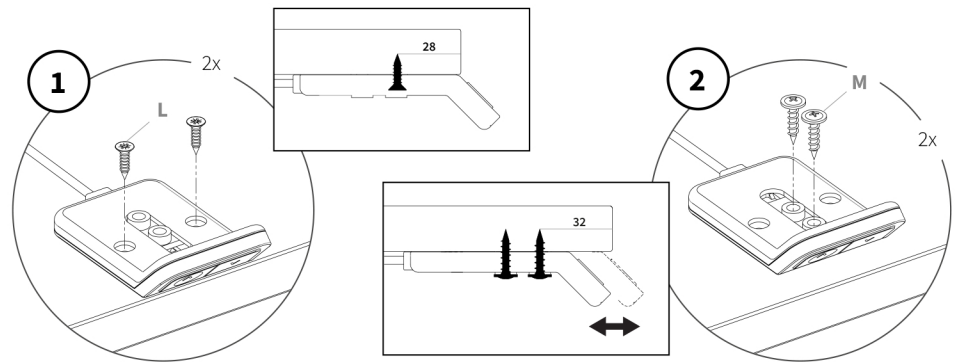

12.

PLACE FOR USER
 PLATS FÖR ANVÄNDARE / PLATZ FÜR BENUTZER

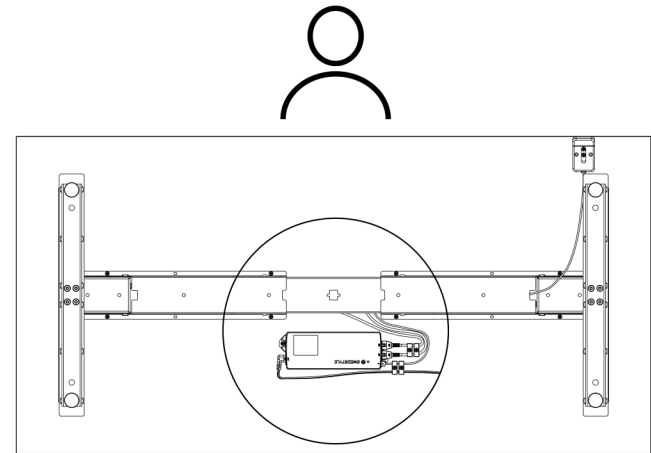
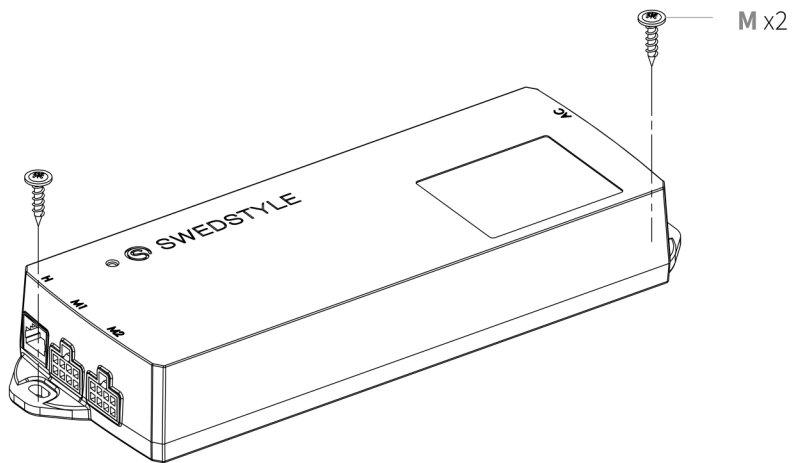
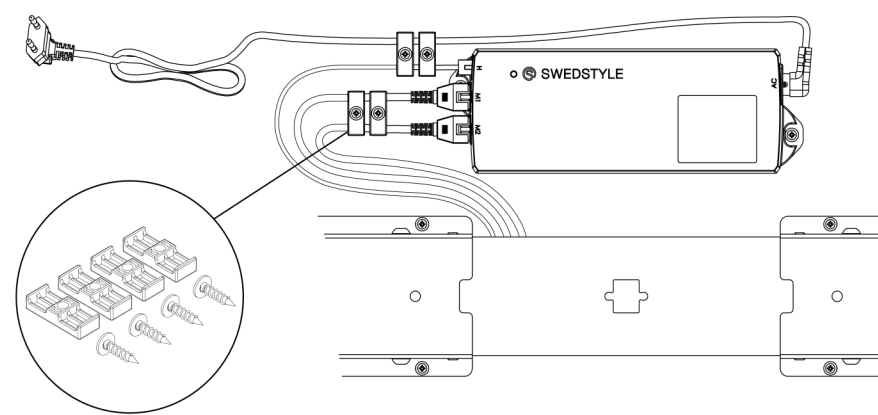

Table seen from below / Bord sett underifrån / Tabelle von unten gesehen

15.



17.



NOTE! This only applies if you have a frame with a built-in sensor activated.

If any of the cables connected to the control box moves, the built-in sensor activates. Therefore, the cables must be fixed to the table top with included cable clamps.

OBS! Detta gäller endast om du har ett stativ med inbyggd sensor aktiverad.

Om någon av kablarna som är inkopplade i styrboxen rör sig utlöses den inbyggda sensorn. Därför måste kablarna vara fixerade i bordsskivan med medföljande kabelklämmor.

ACHTUNG! Folgendes ist nur gültig, wenn Ihr Gestell mit integriertem Sensor ausgestattet ist und dieser aktiviert ist.

Wenn sich eines der an die Steuerbox angeschlossenen Kabel bewegt, wird der eingebaute Sensor aktiviert. Daher müssen die Kabel mit den mitgelieferten Kabelklämmen an der Tischplatte befestigt werden.

16.

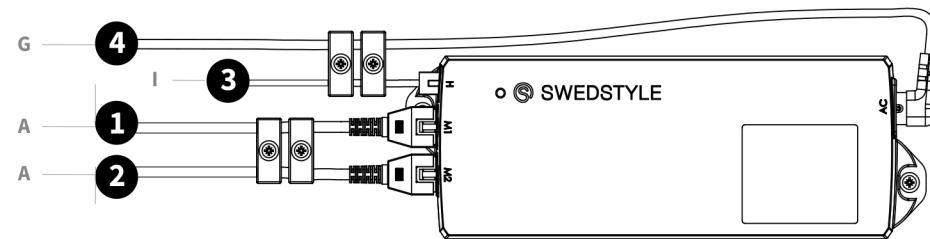

NOTE All cables must be connected to the control box in this specific sequence before you plug in the power.

OBS Alla kablar måste vara inkopplade i styrboxen enligt denna specifika ordning innan stativet strömsätts.

ACHTUNG Alle Kabel müssen in dieser Reihenfolge vor dem Einschalten des Statives an die Steuerbox angeschlossen werden.

18.

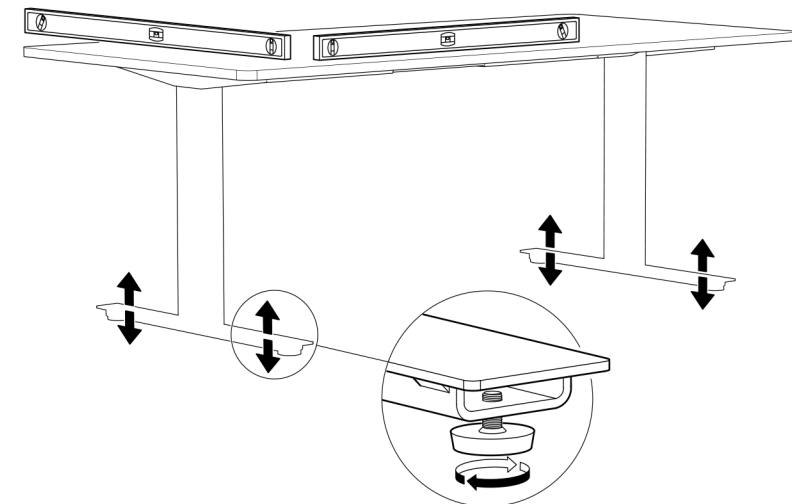

Reset procedure | Nollställning | Resetten

EN

Lower the frame to its lowest position by pressing the down arrow on the hand control.
Release the button. Press the button again and keep it pressed for 10 seconds, the reset is now carried out and the frame is ready to use.

SE

Kör bordet till stativets bottenläge genom att trycka på knappen "pil ned", när stativet nått lägsta läget så släpp knappen. Tryck sedan in den på nytt och håll inne ytterligare 10 sek. Stativet är nu nollställt och redo att användas.

DE

Fahren Sie die Tischplatte mit der Taste "Pfeil nach unten" zum tiefsten Punkt! Die Taste loslassen. Die Taste noch einmal herunterdrücken und sie ca. 10 Sekunden halten bis Sie eine kleine Bewegung der Tischplatte bemerken.

